

Short-Range Modem Pair

OPERATION MANUAL

Catalog No. 3365WD2

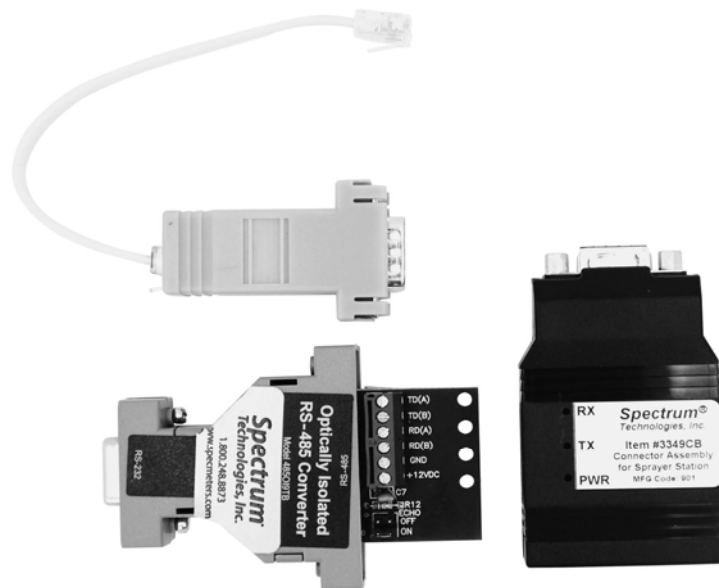

Spectrum
Technologies, Inc.

CONTENTS

General Overview	3
Components	3
Cable Connection	4
Connecting to the Computer	5
Connecting to the Weather Sta-	6
Warranty	7

This manual will familiarize you with the features and operation of your new Short-Range Modem Pair. Please read this manual thoroughly before using your instrument. For customer support, or to place an order, call Spectrum Technologies, Inc. at (800)248-8873 or (815) 436-4440 between 7:30 am and 5:30 p.m. CST, FAX at (815)436-4460, or E-Mail at info@specmeters.com.

Spectrum Technologies, Inc
12360 S. Industrial Dr. East

General Overview

The short-range modem pair will allow you to extend the range of your WatchDog Weather Station up to 4000 ft. Because the station is hardwired to your computer, it is not necessary to have a line of sight with the station.

Components

The components of the short-range modem pair are as follows:

1. Optically Isolated RS-485 Converter
2. 3349CB RS-422 Connector Assembly
3. Short-range modem adaptor and modular connector cable.
4. A/C adapter

The 2 converters must be connected by a length of 6-wire cable (2 twisted pair, 1 ground, 1 voltage). The recommended wire type is number 24 AWG twisted-pair telephone cable with a shunt capacitance of 16 picofarads/foot and a length no greater than 4000 feet.

Cable Connection

The twisted-pair cable should be connected to the two converters and the A/C adaptor as shown in figure 1.

IMPORTANT: the wire connected to a Transmit Data terminal [TD(A) or TD(B)] of one converter must be connected to the corresponding Receive Data terminal [RD(A) or RD(B)] of the other converter.

The ground (GRD) and voltage (12V) terminals of one converter should be connected to the corresponding terminal of the other. The black wire from the A/C adaptor is connected to the GRD terminal of the RS232-RS485 converter. The black/white wire connects to the 12V terminal.

If the case of the 03349CB RS422 Converter has been closed, it can be opened by inserting a screwdriver in the side slots and rotating to separate the halves.

Note: The twisted pair cable should be run through the **right-most** hole in the bottom of the weather station enclosure **before** connecting to the RS232-RS422 converter. The RS232-RS422 converter will then rest inside the weather station enclosure (see photo on page 6).

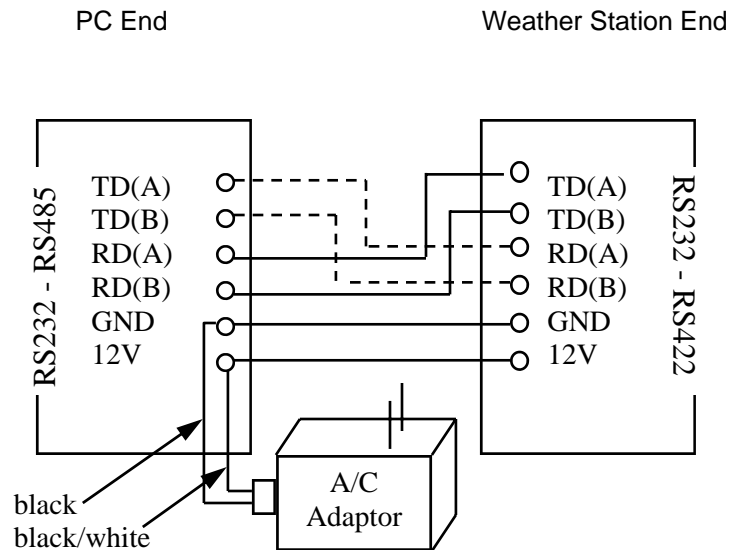

Fig. 1: Component Wiring Diagram

Connecting to the Computer

Before powering the short-range modem pair with the A/C adaptor, check that the jumper clip on the RS232-RS485 converter is in the **Echo-On** position as shown in figure 2.

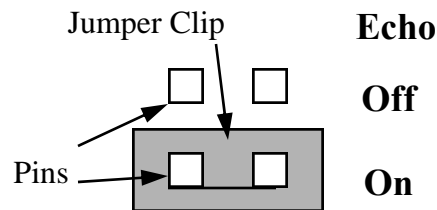

Figure 2: Top view of Echo On/Off switch

The 9-pin female connector of the RS232-RS485 converter connects to the computer data port. This converter is optically isolated so voltage spikes in the twisted-pair cable should not damage your computer.

In SpecWare go to **File** → **Preferences** → **Communication**. Uncheck the **Hardware Flow Control (RTS)** (see fig. 3). This must be unchecked for the modem to work correctly.

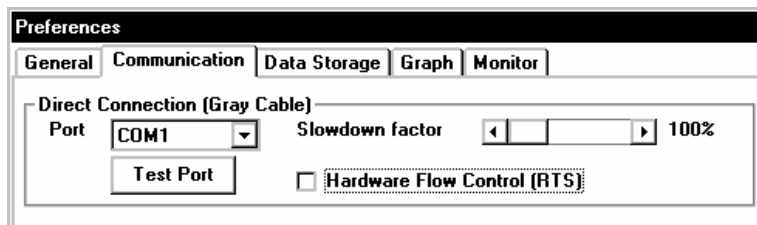

Fig. 3: Hardware Flow Control Option (Specware 7)

Connecting to Weather Station

The 9-pin male connector of the short-range modem adaptor is attached to the 3349CB RS422 converter. The modular connector snaps into the auxiliary port (Aux) of the weather station. Secure the twisted-pair cable into the notch in the right-most hole and snap the cap over the hole. The flat edge of the cap should rest against the cable.

The converter and adapter fit snugly behind the sensor wires as shown in the photo below. This will make it easier to remove and replace external sensor wires.

Note: It is advisable to confirm the connection before installation of the cable.

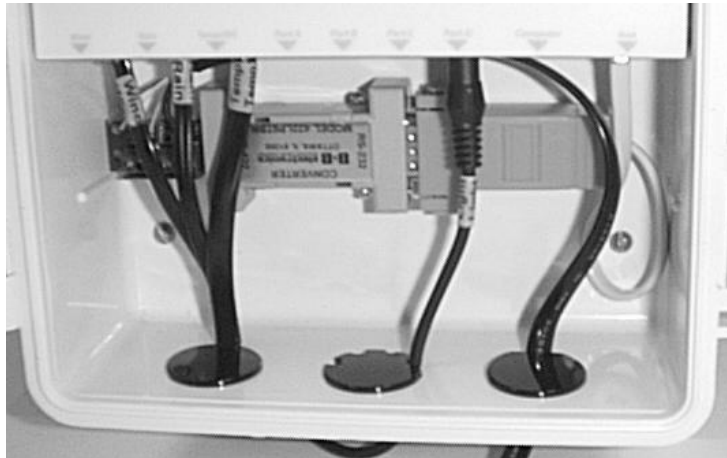

Warranty

This product is warranted to be free from defects in material or workmanship for 1 year from the date of purchase. During the warranty period Spectrum will, at its option, either repair or replace products that prove to be defective. This warranty is void if the Spectrum products have been damaged by customer error or negligence, or if there has been an unauthorized modification.

Returning Products to Spectrum

Before returning a failed unit, you must obtain a Returned Goods Authorization (RGA) number from Spectrum. You must ship the product(s), properly packaged against further damage, back to Spectrum at your expense. Clearly mark the RGA number on the **outside of the package**. Spectrum is not responsible for any package that is returned without a valid RGA number or for the loss of the package by any shipping company.

Spectrum
Technologies, Inc.

Spectrum Technologies, Inc.
12360 S. Industrial Dr. East
Plainfield, IL 60585
(800) 248-8873 or (815) 436-4440
FAX: (815) 436-4460
E-Mail: info@specmeters.com
www.specmeters.com